

公差/General tolerances (mm)											D			
0	>3	>6	>10	>18	>30	>50	>80	>120	>180	>250		>315	>400	>500
±0.12	±0.18	±0.22	±0.26	±0.31	±0.37	±0.57	±0.80	±0.93	±1.05	±1.15	±1.60	±2.20	±2.50	0.1/10
													±2	

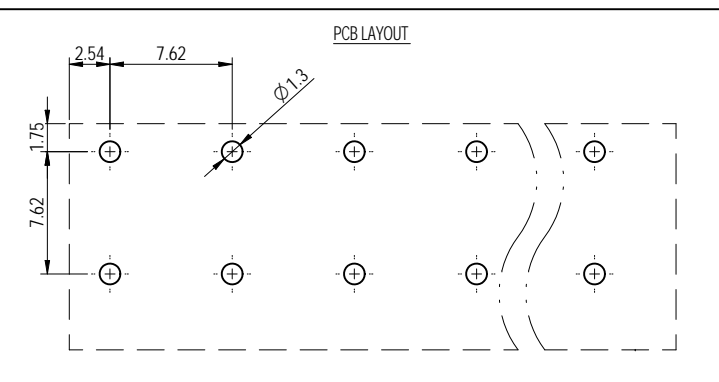
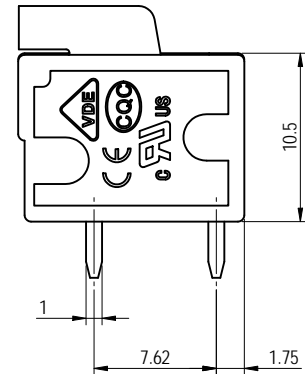
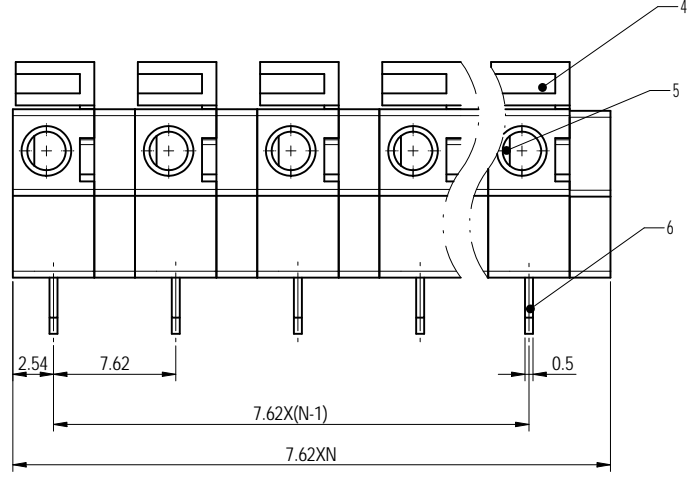
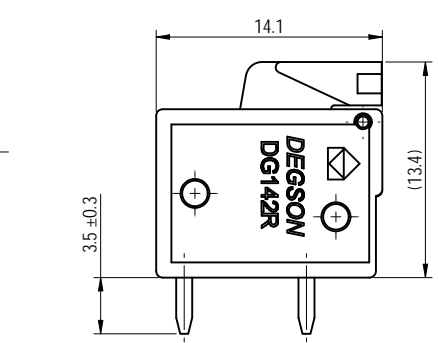
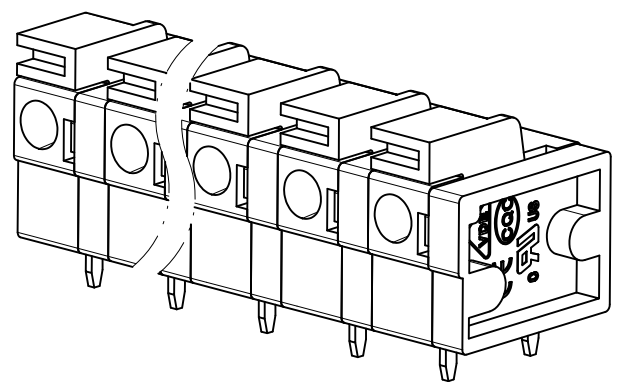
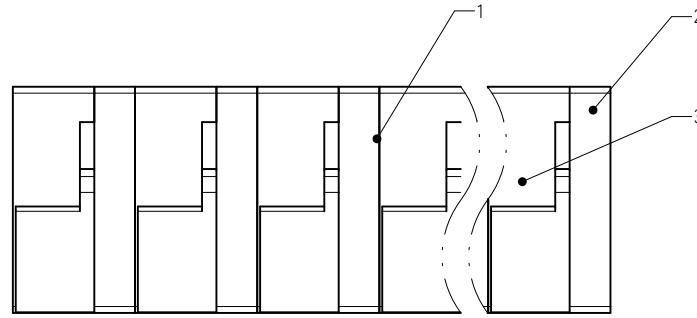
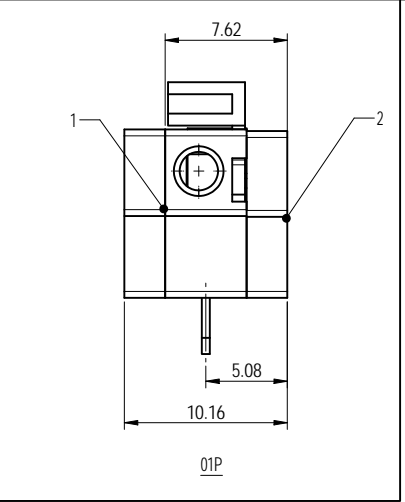

Note:  
The A&Z(H) in the name means: A(H) and Z(H).

ITEM	NAME OF PART	MATERIAL	NOTES
6	Pin header	Copper alloy	Sn plated
5	Spring	Stainless steel	/
4	Button	PA66	UL94V-0
3	Housing	PA66	UL94V-0
2	Cover	PA66	UL94V-0
1	Clapboard	PA66	UL94V-0

UL 标准/UL Standard:	B	C	D
额定电压/电流/Rated Voltage(V)/Current(A)	300/10	300/10	300/10
IEC 标准/IEC Standard:			
过压类别/Overvoltage Category/污染等级/Pollution Degree	III/3	III/2	II/2
额定电压/电流/Rated Voltage(V)/Current(A)	/	450/15	/
工频耐压/Withstanding Voltage(V/1Min)	AC2500		
线径范围(硬线和软线)/Wire Range(rigid and flexible)(AWG/mm <sup>2</sup> )	22~16 / 0.2~1.5		
间距/Pitch(mm)/线数范围/Poles	7.62/N=02~16P		
剥线长度/Stripping length(mm)	10		
使用温度范围/Operating temperature(°C)	-40~+105		
符合RoHS环保要求/Conform to RoHS	Yes		

**DIAGSON** MATERIAL: SURFACE/COLOR: / 00 MAT STATUS: 批量

APPD: 兰春华 2022.09.29 NAME: DG142R-7.62-XXP-1Y-00A&Z(H)

CHKD: 陈超 2022.09.28

DRFT: 姜徐涛 2022.09.28

DRAWING NO. 200029092 TYPE CUSTOMER DRAWING DRAWING STATUS 已发布 SCALE 3:1 SHEET 1/1

REV	ECN	DESCRIPTION	DRFT	DATE
00			姜徐涛	2022.09.28

Transfer or duplication of this document as well as the utilization of its contents without the written permission of the copyright holder is prohibited. All rights reserved for patent. 本文件及其中所载之内容之复制或未经权利人书面许可之使用均被禁止。保留所有权利。未经许可，不得复制或传播本文件之内容。