

未注公差/General tolerances (mm)													0.1/10	
0	>3	>6	>10	>18	>30	>50	>80	>120	>180	>250	>315	>400		
~3	~6	~10	~18	~30	~50	~80	~120	~180	~250	~315	~400	~500	>500	
±0.12	±0.18	±0.22	±0.26	±0.31	±0.37	±0.57	±0.80	±0.93	±1.05	±1.15	±1.60	±2.20	±2.50	±2'

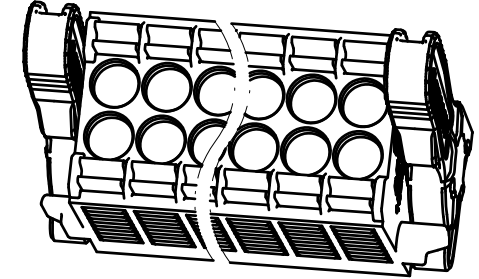
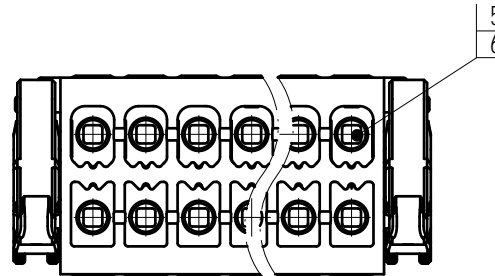
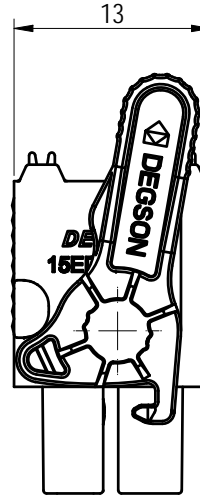
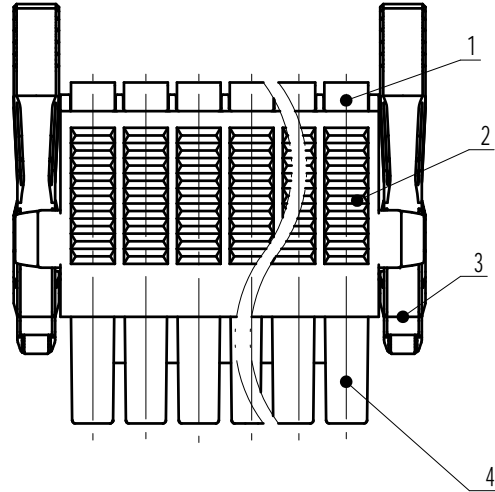
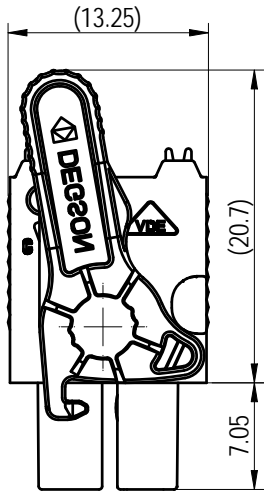
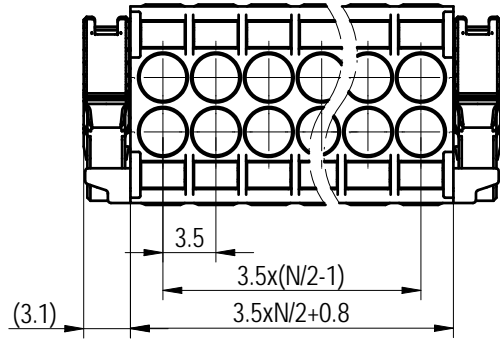

Note:
The A&Z (H) in the name means: A(H) and Z(H).

ITEM	NAME OF PART	MATERIAL	NOTES
6	Spring	Stainless steel	/
5	Clamp	Copper alloy	Sn Plated
4	Cover	PA66	UL94V-0
3	Card hook	PA66-GF	UL94V-0
2	Housing	PA66	UL94V-0
1	Button	POM	UL94HB

UL 标准/UL Standard:	B	C	D
额定电压/电流/Rated Voltage(V)/Current(A)	300/8	50/8	/
IEC 标准/IEC Standard:			
过压类别/Overvoltage Category/污染等级/Pollution Degree	III/3	III/2	II/2
额定电压/电流/Rated Voltage(V)/Current(A)	200/9.5	250/9.5	320/9.5
额定脉冲电压 (KV)/Rate Impulse Voltage(KV)	2.5	2.5	2.5
线径范围(硬线和软线)/Wire Range(rigid and flexible)(AWG/mm²)	26~16 / 0.2~1.5		
间距/Pitch(mm)/线数范围/Poles	3.5/N=04~48P		
剥线长度/Stripping length(mm)	10		
使用温度范围/Operating temperature(°C)	-40~+105		
符合RoHS环保要求/Conform to RoHS	Yes		

DEGSON

APPD: 兰春华 2022.08.05
CHKD: 龚耀志 2022.08.05
DRFT: 刘强 2022.08.04

MATERIAL:	SURFACE/COLOR:		
MAT NO./REV:	/ 00	MAT STATUS: 批量	
NAME	15EDGKNHG-3.5-XXP-1Y-00A&Z(H)		
DRAWING NO.	TYPE	DRAWING STATUS	SCALE
200029880	CUSTOMER DRAWING	已发布	2:1
SHEET		1/1	

REV	ECN	DESCRIPTION	DRFT	DATE
00			刘强	2022.08.04

Transfer or duplication of this document as well as the utilization or communication of its contents are prohibited unless explicit authorization is granted. Violations will be liable for compensation. All rights reserved for patent, utility model or design registrations. 除专利等明确授权外, 复制、翻译、分发本文档内容, 或未经明确授权擅自使用, 均属于侵权行为, 侵权者将承担相关法律责任。 未经授权, 复制或传播本文件内容, 或未经明确授权擅自使用, 均属于侵权行为, 侵权者将承担相关法律责任。