

PCB LAYOUT

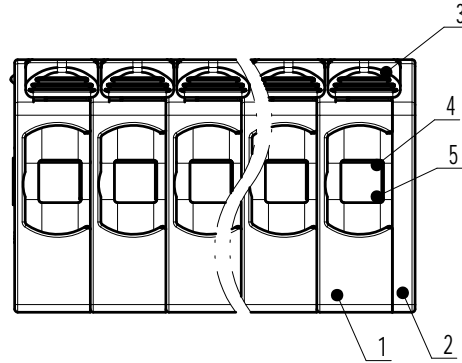

未注公差/General tolerances (mm)													0.1/10	
0	>3	>6	>10	>18	>30	>50	>80	>120	>180	>250	>315	>400		>500
~3	~6	~10	~18	~30	~50	~80	~120	~180	~250	~315	~400	~500	>500	
±0.12	±0.18	±0.22	±0.26	±0.31	±0.37	±0.57	±0.80	±0.93	±1.05	±1.15	±1.60	±2.20	±2.50	±2'

UL 标准/UL Standard:	B	C	D
额定电压/电流/Rated Voltage(V)/Current(A)	300/20	/	300/10
IEC 标准/IEC Standard:			
过压类别/Overvoltage Category/污染等级/Pollution Degree	III/3	III/2	II/2
额定电压/电流/Rated Voltage(V)/Current(A)	320/32	400/32	630/32
额定脉冲电压(KV)/Rate Impulse Voltage(KV)	4	4	4
线径范围(硬线和软线)/Wire Range(rigid and flexible)(AWG/mm ²)	24~12 / 0.2~4		
间距/Pitch(mm)/线数范围/Poles	5.0/N=01~12P		
剥线长度/Stripping length(mm)	9~11		
使用温度范围/Operating temperature(°C)	-40~+105		
符合RoHS环保要求/Conform to RoHS	Yes		

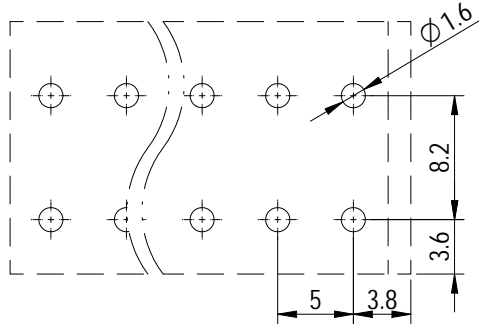
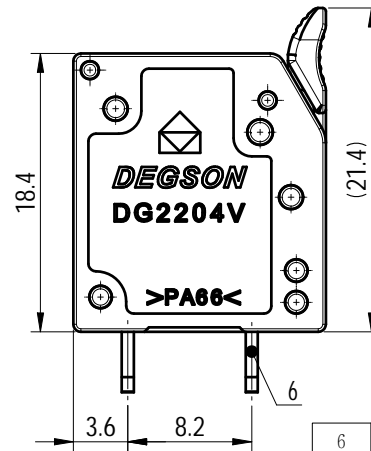
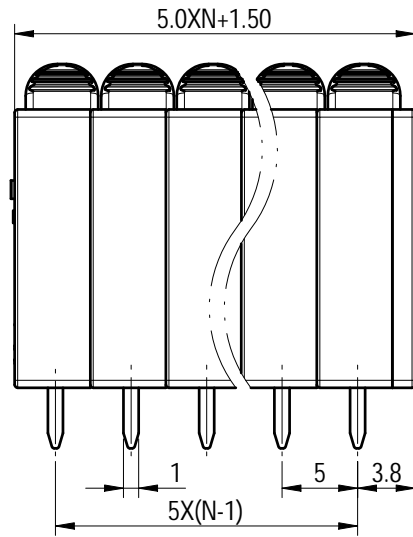
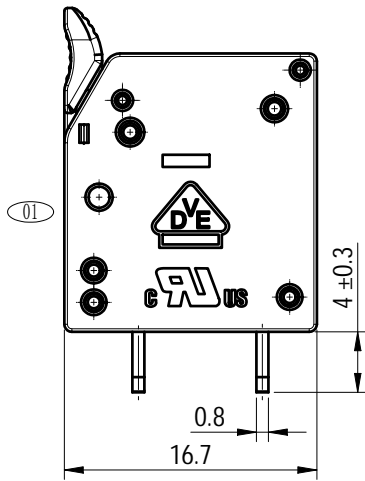

ITEM	NAME OF PART	MATERIAL	NOTES
6	Pin header	Copper	Sn Plated
5	Spring	Stainless steel	/
4	Block	Stainless steel	/
3	Lever	PA66-GF	UL94V-0
2	Cover	PA66	UL94V-0
1	Housing	PA66	UL94V-0

		MATERIAL:		SURFACE/COLOR:	
		MAT NO./REV: - / 00		MAT STATUS: 批量	
APPD: 兰春华	2023.07.13	NAME			
CHKD: 张玉华	2023.07.13	DG2204V-5.0-XXP-1Y-00Z(H)			
DRFT: 申玉堂	2023.07.12				
DRAWING NO.	TYPE	DRAWING STATUS	SCALE	SHEET	
200119960	CUSTOMER DRAWING	已发布	2:1	1/1	

REV	ECN	DESCRIPTION	DRFT	DATE
01		1X增加VDE刻字/1X Add VDE certification mark	申玉堂	2023.07.12

Transfer or duplication of this document as well as the utilization or communication of its contents are prohibited unless authorized in writing by DEGSON. All rights reserved for patent. 除专利注明情况外，其他内容均受版权保护。未经许可，不得复制或传播。