

未注公差/General tolerances(mm)											0.05/10			
0	>3	>6	>10	>18	>30	>50	>80	>120	>180	>250		>315	>400	>500
~3	~6	~10	~18	~30	~50	~80	~120	~180	~250	~315	~400	~500	>500	
±0.08	±0.12	±0.18	±0.22	±0.26	±0.31	±0.37	±0.57	±0.80	±0.93	±1.05	±1.15	±1.60	±2.20	±1°

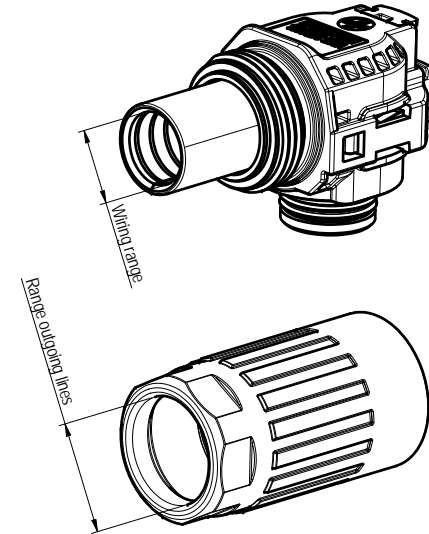
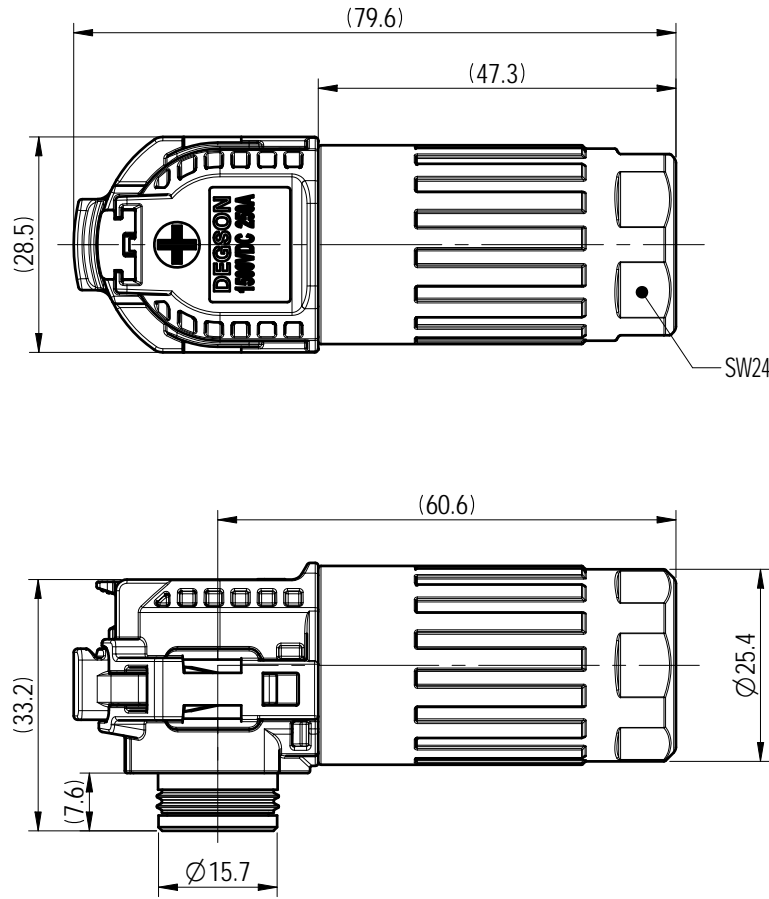

技术要求/Technical requirements:	
额定电压电流/Rated Voltage/Current	1500V DC/ 250A
绝缘电阻/Insulate Resistance 干燥	>5000MΩ,500VDC 1min
绝缘电阻/Insulate Resistance 湿态	>100MΩ,500VDC 1min
耐压/Withstanding Voltage	6800V AC
防护等级/Ingress Protection	IP67 (耦合)
使用温度范围/Operating temperature(°C)	-40~+125
设计标准/Design standards	UL、TUV
耐盐雾/Resistance to salt fog	48小时(5%盐) (耦合)
初始接触电阻/Contact resistance(initial)	≤0.3mΩ
温升/Temperature rise	ΔT<45K,静态, 包裹后
包装规范/Packaging specification	SOP-Y-3141
接线方式/Terminal	Crimp
压接刀模宽度建议/Width suggestion	Assembly instructions
正六边形压接,对边尺寸建议/Size suggestion	Assembly instructions
接线范围/Connection range 特指:线缆导体截面积	S=65~70mm² or AWG:2/0
出线范围/Connection range 特指:线缆外被直径	OD=φ 16.5~17.5 mm
符合RoHS环保要求/Conform to RoHS	<input checked="" type="checkbox"/> RoHS <input type="checkbox"/> RoHS2.0

		MATERIAL: 材质	SURFACE/COLOR: 表面处理		
		MAT NO./REV: 28010000399 / 00	MAT STATUS: 物料状态		
APPD: 核准人	核准日期	NAME			
CHKD: 审核人	审核日期	ESP-250A-70-OR-00 (A1)			
DRFT: 设计人	设计日期	DRAWING NO.	TYPE	DRAWING STATUS	SHEET
		200301547	图纸类型	图纸状态	1/1

图纸版本	ECN	变更描述	设计人	设计日期
REV	ECN	DESCRIPTION	DRFT	DATE

Transfer or duplication of this document as well as the utilization or communication of its contents are prohibited unless authorized in writing by DEGSON. All rights reserved for patent, utility model or design registrations. 除专利等权利外, 未经授权, 不得复制或传播, 否则将承担法律责任。 凡属 DEGSON 公司之知识产权, 未经授权, 不得复制或传播, 否则将承担法律责任。