

公差表(General tolerances)(mm)													D	
0	>3	>6	>10	>18	>30	>50	>80	>120	>180	>250	>315	>400	>500	0.1/10
~3	~6	~10	~18	~30	~50	~80	~120	~180	~250	~315	~400	~500	~500	N
±0.12	±0.18	±0.22	±0.26	±0.31	±0.37	±0.57	±0.80	±0.93	±1.05	±1.15	±1.60	±2.20	±2.50	±2

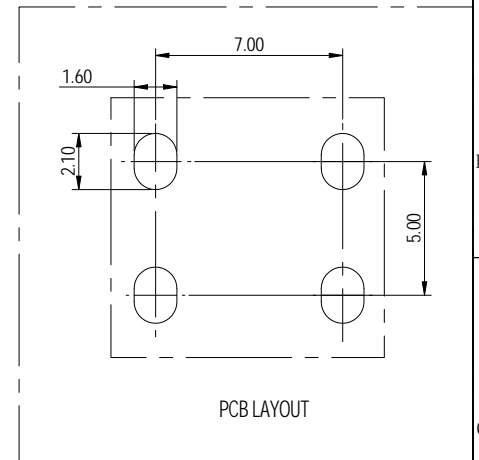
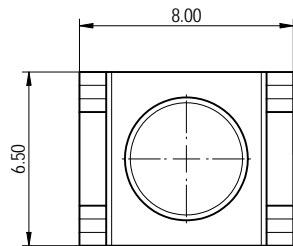
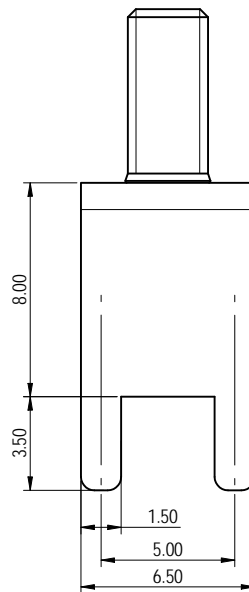
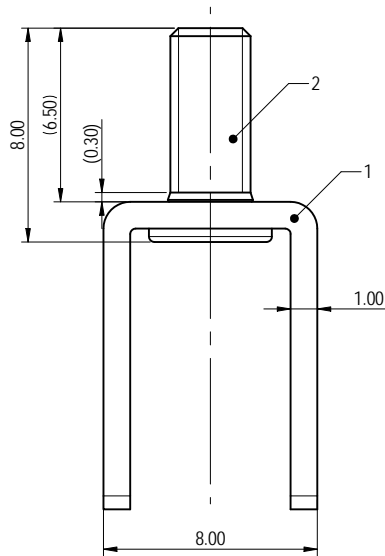

2	Screw	Steel	Zn Plated
1	Pin header	Copper alloy	Sn Plated
ITEM	NAME OF PART	MATERIAL	NOTES
额定电压/Rated Voltage(V)			63A
螺丝扭矩/Torque Tightening(N·m/Lb·in)			M3 1.20/10.59
使用温度范围/Operating temperature(°C)			-40--+135
符合RoHS环保要求/Conform to RoHS			Yes

DEGSON		MATERIAL:		SURFACE/COLOR:	
APPD: 蓝黄凡	2023.12.28	MAT NO./REV: 10900000344 / 00		MAT STATUS: 小批量	
CHKD: 曹利影	2023.12.28	NAME: K160-00Z(H)			
DRAFT: 孙科豪	2023.12.28	DRAWING NO. 200262082	TYPE: CUSTOMER DRAWING	DRAWING STATUS: 已发布	SCALE: 1:1
REV: 00	ECN:	DESCRIPTION:	DRAFT:	DATE:	SHEET: 1/1

Transfer or duplication of this document as well as the utilization or reproduction of its contents without the written permission of DEGSON is prohibited. All rights reserved for patent. 复制或再行发布此文件以及未经 DEGSON 书面许可擅自使用其内容均属于侵权行为。如有侵权，请即通知，我们将依法追究。 版权所有，保留所有权利。