

### ◆ 4 channel RTD measurement /RT100、 RT1000(DF20-M-4RTD-PT)

- The module supports 4-channel RTD thermal resistance temperature acquisition, supports 13 kind of conventional resistance temperature measurement type.
- The module could be connected to a 2-wire or 3-wire (PT100、 PT1000) temperature sensor.
- The two LED indicators respectively indicate the normal operation and communication of the module.
- Each channel is equipped with an LED indicator.
- Field and system levels are Magnetic isolated.
- Transmitted with a resolution of 16 bits.
- Protection level IP20.

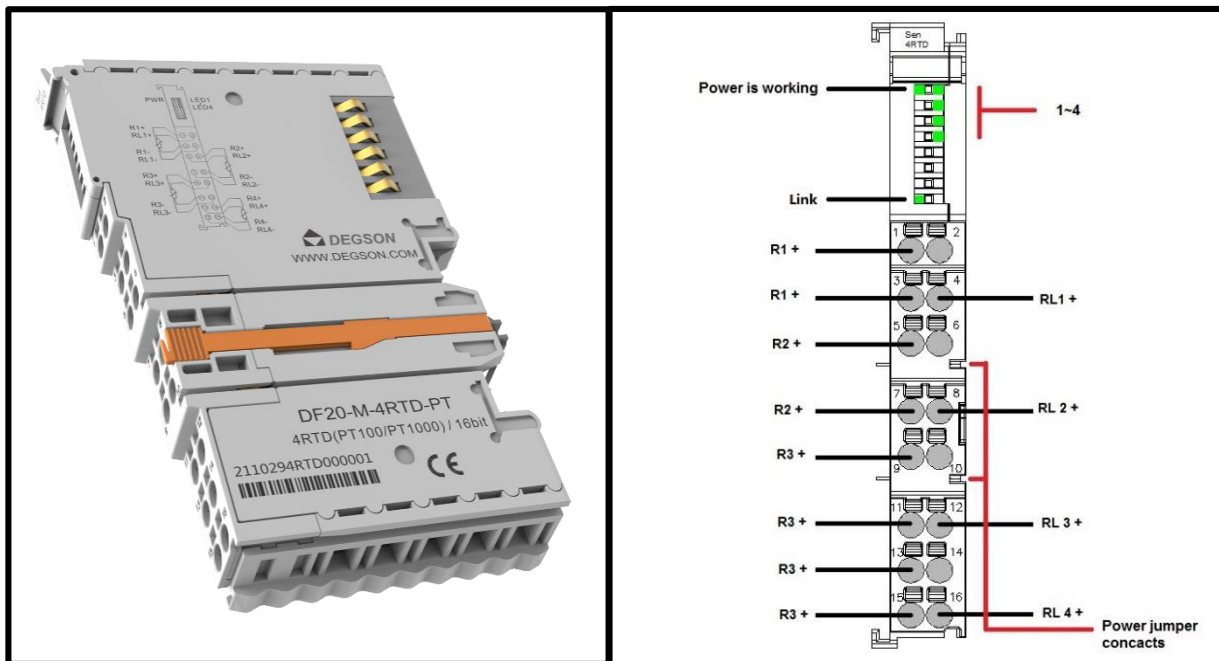

## 1. Specification

<b>Technical data</b>	
Number of channels	4
Signal type	Thermal resistance
Signal type	PT100、PT200、PT500、PT1000、NI100、NI200、NI500、NI1000、NI120、CU10、CU50、CU100、CU53
Connection type	2/3-line
Resolution [bit]	16 Bit, 0.1°C/each number
Precision	±0.3%
Data size	8 Byte
Temperature coefficient	±50ppm/Kmax.
Measuring range	-200°C~850°C
Supply voltage (system)	5VDC; via data contacts
Current consumption	<100mA
Working voltage	24VDC (-15%~+20%) via power jumper contacts
Isolation	500Vsystem/field Magnetic isolation
Frequency interference suppression	10Hz   50Hz   60Hz   400Hz
Conversion time	200ms
Fault diagnosis	Yes
Diagnosis	Disconnection, Parameter assignment error
Process alarm	Upper/Lower limit, per channel
Reverse protection	Yes
Indicators	6x LED Green
Number of incoming power jumper contacts	2
Number of outgoing power jumper contacts	2
<b>Connection data</b>	
Connection technology: inputs / outputs	16 x via pluggable connector
Connection type 1	Inputs/Outputs
Area of wire	0.2~1.5mm <sup>2</sup> /28~16AWG
Strip length	8~9mm/0.31~0.35inches
Mounting type	DIN-35 RAIL
<b>Material Data</b>	
Color	light gray
Housing material	Polycarbonate; polyamide 6.6
Conformity marking	CE
<b>Environmental requirements</b>	
Ambient temperature (operation)	-25~60°C
Surrounding air temperature (storage)	-40~85°C
Protection type	IP20
Pollution degree (5)	2, Per IEC 61131-2
Operating altitude	without temperature derating: 0~2000m
Mounting position	Any
Relative humidity (without condensation)	5~95%RH
Vibration resistance	4g, Per IEC 60068-2-6
Shock resistance	15g, Per IEC 60068-2-27
EMC immunity to interference	Per EN 61000-6-2
EMC emission of interference	Per EN 61000-6-3
Exposure to pollutants	Per IEC 60068-2-42 and IEC 60068-2-43
Permissible pollutant concentration H <sub>2</sub> S at a relative humidity < 75%	10ppm
Permissible pollutant concentration SO <sub>2</sub> at a relative humidity < 75%	25ppm

## 2. Hardware Interface

### ● Wiring Terminal

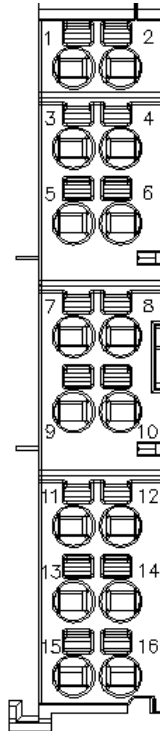

No.		Signal		Description
1	2	R1 +	/	Signal Input CH 1
3	4	R1 -	RL1 -	
5	6	R2 +	/	Signal Input CH 2
7	8	R2 -	RL2 -	
9	10	R3 +	/	Signal Input CH 3
11	12	R3 -	RL3 -	
13	14	R4 +	/	Signal Input CH 4
15	16	R4 -	RL4 -	

## ● LED Indicator

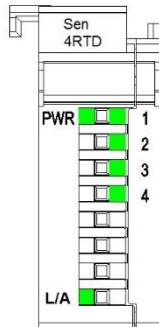

LED Indicator	State		Definition
PWR	Green:ON		Power Normal
	Green:OFF		Power Failure
L/A	Power-on	Green:ON	Module is being initialized
		Green:OFF	Module initialization is complete
	Running	Green: Flash	The module runs normally
		Green:OFF	Module operating fault
1	Green:Flash		CH 1 is normally sampled
	Green:ON		Value :exceeds limit
	Green:OFF		Disconnection
2	Green:Flash		CH 2 is normally sampled
	Green:ON		Value :exceeds limit
	Green:OFF		Disconnection
3	Green:Flash		CH 3 is normally sampled
	Green:ON		Value :exceeds limit
	Green:OFF		Disconnection
4	Green:Flash		CH 4 is normally sampled
	Green:ON		Value :exceeds limit
	Green:OFF		Disconnection

## ● Wiring

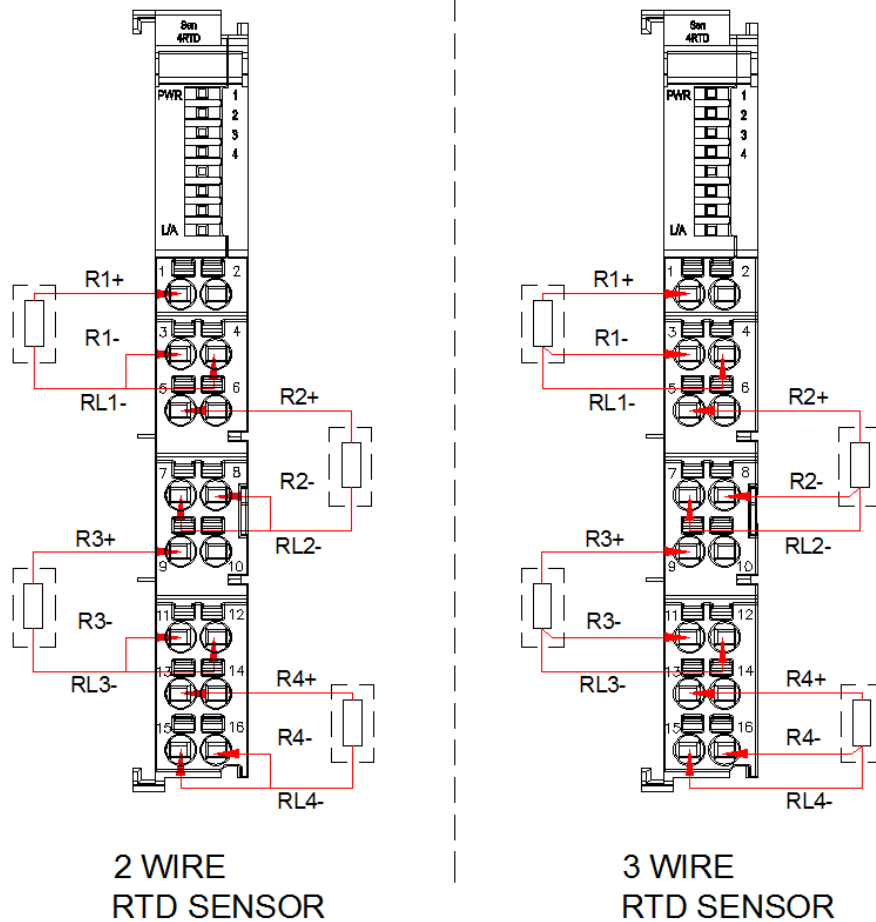

As shown in the picture:

Take the connection method of one channel on the module as an example. The other channels are connected in the same way

- (1) 3-wire sensor: Connect to ports 1, 5 and 7.
- (2) 2-wire sensor: Connect ports 1 and 5 (5 and 7 are short-circuited).

### 3.Process data definition

#### DF20-M-4RTD-PT Module process data definition

Input data									
Bit No	Bit 7	Bit 6	Bit 5	Bit 4	Bit 3	Bit 2	Bit 1	Bit 0	Data type
Byte 0	Analog Input Data(Channel 1)								Int16
Byte 1									
Byte 2	Analog Input Data(Channel 2)								Int16
Byte 3									
Byte 4	Analog Input Data(Channel 3)								Int16
Byte 5									
Byte 6	Analog Input Data(Channel 4)								Int16
Byte 7									

#### Data description:

Analog Input Data(Channel 1~4): Analog signal Input value of corresponding channel.

Analog Input Data (DF20-M-2RTD-PT) —PT100/PT200/PT500		
Temperature (°C)	Decimal	
>860	32767	Exceeds the upper limit
860	8600	Overflow
850	8500	Rated range
...	...	
...	...	
-200	-2000	
-210	-2100	Underflow
<-210	-32767	Exceeds the lower limit
Line break	-32768	Line break
Analog Input Data (DF20-M-2RTD-PT) —PT1000		
Temperature (°C)	Decimal	
>860	32767	Exceeds the upper limit
860	8600	Overflow
850	8500	Rated range
...	...	
...	...	
-200	-2000	
-204	-2040	Underflow
<-204	-32767	Exceeds the lower limit
Line break	-32768	Line break
Analog Input Data (DF20-M-2RTD-PT) —NI100/NI200/NI500/NI1000		
Temperature (°C)	Decimal	
>254	32767	Exceeds the upper limit

254	2540	Overflow
250	2500	Rated range
...	...	
...	...	
-60	-600	
-64	-640	Underflow
<-64	-32767	Exceeds the lower limit
Line break	-32768	Line break
<b>Analog Input Data (DF20-M-2RTD-PT) —NI120</b>		
Temperature (°C)	Decimal	
>313	32767	Exceeds the upper limit
313	3130	Overflow
309	3090	Rated range
...	...	
...	...	
-79	-790	
-83	-830	Underflow
<-83	-32767	Exceeds the lower limit
Line break	-32768	Line break
<b>Analog Input Data (DF20-M-2RTD-PT) —CU10/CU50/CU100</b>		
Temperature (°C)	Decimal	
>163	32767	Exceeds the upper limit
163	1630	Overflow
159	1590	Rated range
...	...	
...	...	
-59	-590	
-63	-630	Underflow
<-63	-32767	Exceeds the lower limit
Line break	-32768	Line break
<b>Analog Input Data (DF20-M-2RTD-PT) —CU53</b>		
Temperature (°C)	Decimal	
>154	32767	Exceeds the upper limit
154	1540	Overflow
150	1500	Rated range
...	...	
...	...	
-50	-500	
-54	-540	Underflow
<-54	-32767	Exceeds the lower limit
Line break	-32768	Line break

## 4. Machinery installation

- Dimension drawing

The installation size is shown in the following figure (unit: mm):

