

◆ 1 channel encoder input/ pulse output/ 5VDC (DF20-M-1CNT-ELP-5)

- The module supports one channel of encoder input, Input signal voltage 5VDC, pulse output.
- The two LED indicators respectively indicate the normal operation and communication of the module.
- Field and system levels are Magnetic isolated.
- Transmitted with a resolution of 16 bits.
- Protection level IP20.

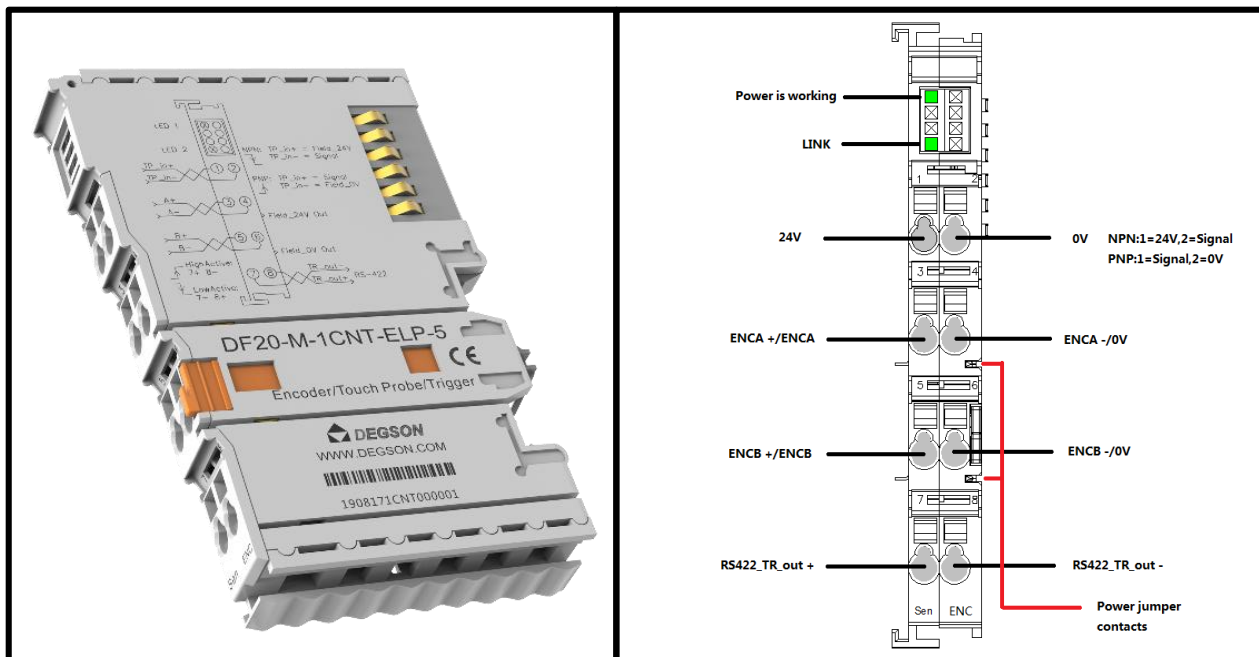

1. Specification

Technical data	
Number of channels	1
Maximum frequency count	1Mhz
Input signal type	Incremental encoder
Input signal voltage	5VDC
Input connection type	4-line
Output signal type	422 type
Resolution [bit]	32 Bit
Precision	± 1 pulse
Data size	12 Byte
Supply voltage (system)	5VDC; via data contacts
Current consumption	<200mA
Working voltage	24VDC (-15%~+20%) via power jumper contacts
Isolation	500Vsystem/field Magnetic isolation
Fault diagnosis	Yes
Reverse protection	Yes
Indicators	2 x LED Green
Number of incoming power jumper contacts	2
Number of outgoing power jumper contacts	2
Connection data	
Connection technology: inputs / outputs	8 xvia pluggable connector
Connection type 1	Inputs/Outputs
Area of wire	0.2~2.5mm ² /28~14AWG
Strip length	8~9mm/0.31~0.35inches
Mounting type	DIN-35 RAIL
Material Data	
Color	light gray
Housing material	Polycarbonate; polyamide 6.6
Conformity marking	CE
Environmental requirements	
Ambient temperature (operation)	-25~60°C
Surrounding air temperature (storage)	-40~85°C
Protection type	IP20
Pollution degree (5)	2, Per IEC 61131-2
Operating altitude	without temperature derating: 0~2000m
Mounting position	Any
Relative humidity (without condensation)	5~95%RH
Vibration resistance	4g, Per IEC 60068-2-6
Shock resistance	15g, Per IEC 60068-2-27
EMC immunity to interference	Per EN 61000-6-2
EMC emission of interference	Per EN 61000-6-3
Exposure to pollutants	Per IEC 60068-2-42 and IEC 60068-2-43
Permissible pollutant concentration H2S at a relative humidity < 75%	10ppm
Permissible pollutant concentration SO 2 at a relative humidity < 75%	25ppm

2. Hardware Interface

● Wiring Terminal

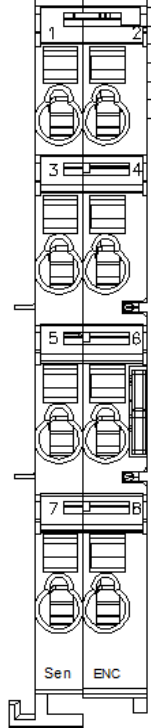

No.	Signal	Description
1	24V	NPN: No.1 connect 24V, No.2 connect low effective signal PNP: No.1 connect high effective signal, No.2 connect 0V
2	0V	
3	A+	5V Signal input
4	A-	
5	B+	
6	B-	
7	RS 422 output +	Pulse output
8	RS 422 output -	

● LED Indicator

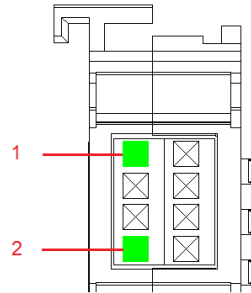

LED Indicator	State		Definition
1	Green:ON		Power Normal
	Green:OFF		Power Failure
2	Power-on	Green:ON	Module is being initialized
		Green:OFF	Module initialization is complete
	Running	Green: Flash	The module runs normally
		Green:OFF	Module operating fault

● Wiring

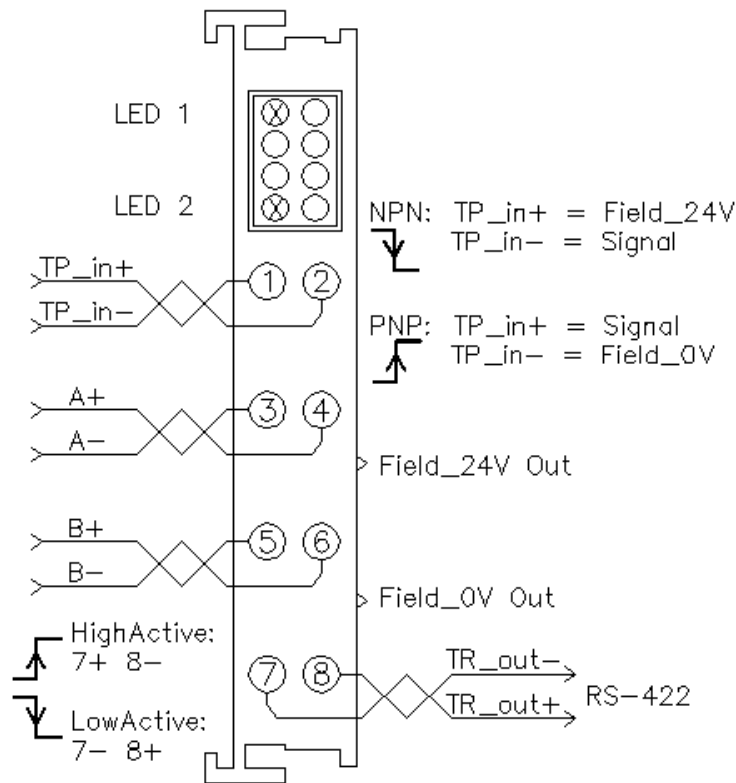

As shown in the picture:

Incremental encoder input A+/A- and B+/B- corresponding pins 3, 4, 5, 6;

The electron probe input corresponds to pin 1 and pin 2. The module supports NPN switch input by default, that is, pin 1 is connected to 24V inside and pin 2 is connected to low effective signal outside;

Pin 7 and pin 8 are connected to pulse signal output. When the output signal is highly effective, pin 7 is negative signal and pin 8 is positive signal; When the output signal is low effective, 7, 8 pin switch.

3.Process data definition

DF20-M-1CNT-ELP-5 Module process data definition

Output data									
Bit No	Bit 7	Bit 6	Bit 5	Bit 4	Bit 3	Bit 2	Bit 1	Bit 0	Data type
Byte 0	Command data								Uint16
Byte 1									
Input data									
Bit No	Bit 7	Bit 6	Bit 5	Bit 4	Bit 3	Bit 2	Bit 1	Bit 0	Data type
Byte 0	State data								Uint16
Byte 1									
Byte 2	Encoder data is 16 bits high								Int32
Byte 3									
Byte 4									
Byte 5	Encoder data is 16 bits lower								
Byte 6	The electron probe is 16 bits high								Int32
Byte 7									
Byte 8									
Byte 9	The electron probe latch is 16 bits lower								

Output data definition

Byte 0	0x010B: State of sampling 0x010C: Data zeroing status
Byte 1	0x010E: State of error 0x0109: Idle state

Input data definition

Byte 0	0x010B: State of sampling 0x010C: Data zeroing status
Byte 1	0x010E: State of error 0x0109: Idle state
Byte 2	Data range: -2147483648~2147483647
Byte 3	
Byte 4	
Byte 5	
Byte 6	Data range: -2147483648~2147483647
Byte 7	
Byte 8	
Byte 9	

4.Machinery installation

● Dimension drawing

The installation size is shown in the following figure (unit: mm):

